

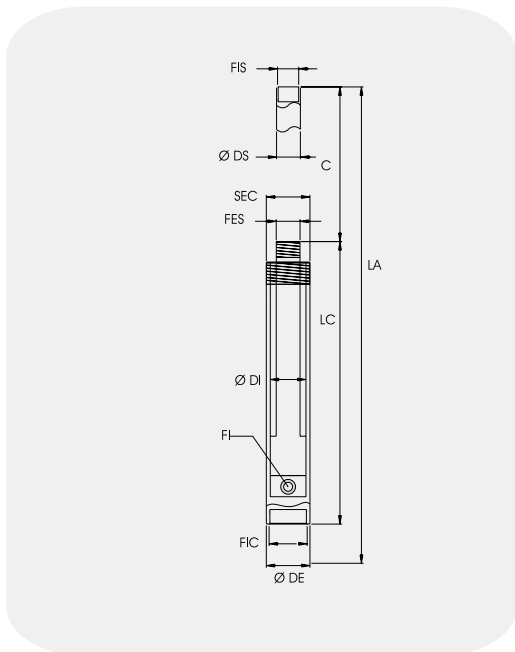

MC CAR

REF.
MCCAR

CARACTERISTIQUES TECHNIQUES



PUISSANCE	10
PUISSANCE	22046
PRESSION (BAR)	700
PRESSION (PSI)	10150
CAPACITÉ D'HUILE	1
RETOUR	Resort
FIL EXT. CYLINDRE	-
FIL INT. CYLINDRE	-
DIAMÈTRE EXTÉRIEUR	50mm / 1,97"
DIAMÈTRE EXTÉRIEUR	45mm / 1,77"
EXÉCUTER (C)	310mm / 12,20"
FIL EXT. TIGE	-
FIL INT. TIGE	-
DIAMÈTRE DE LA TIGE	-
HAUTEUR FERMÉE	560mm / 22,05"
HAUTEUR ÉTENDU	860mm / 33,86"
FILETAGE DU COUPLEUR	3/8" Gas
POID (KG)	7,5
POID (LB)	16,53

FLEXIBLE

REF.
RRFLEX



POMPE GHIBLI

Slift - Easy lift - Spider rolling lift

REF.
IT2500

